

Submersible Wastewater Pumps

Single Vane impeller with 2" Solid Size

Combined 2" and 2 1/2" Discharge

TP 50 M



Performance

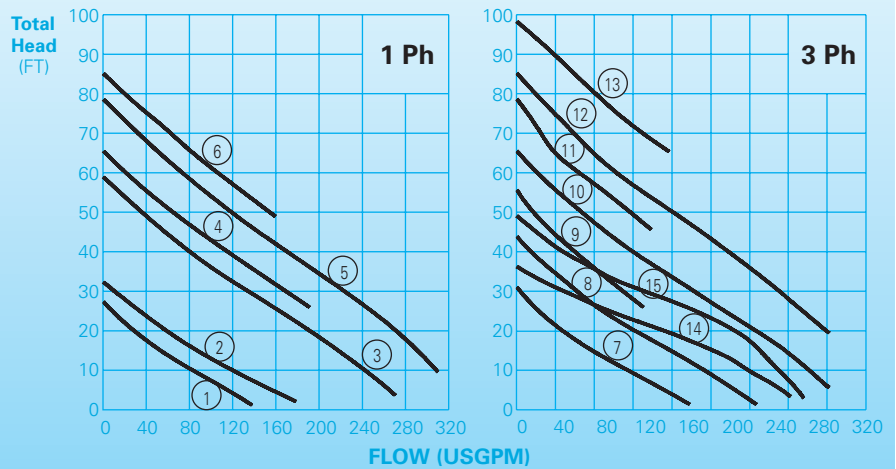

Application

The HOMA TP 50 Series of submersible pumps are ideal for wastewater and sewage service in residential, commercial and industrial applications. The TP 50 is also excellent for drainage applications where large solids are present.

Typical Fluids Handled Are:

- Clear and Drainage Water
- Effluent and Sewage with Soft Solids
- Liquids to 140 F can be handled intermittantly
- PH Range 5 – 9 with Specific Gravity to 1.1

TP 50 Series pumps are typically used in:

- Residential and Commercial Sewage
- Industrial Wastewater
- Effluent Distribution Systems
- Agricultural Wastewater
- Pond or Lake Water
- Processing Plants
- Optional Factory Mutual (FM) label for Class I, Div 1 EX construction.

Features

Integral Lift Handle is arched to permit self centering of lifting device

Cast Iron Construction with Epoxy Coating for maximum corrosion resistance

Extra Long Replaceable power cable of 33' length is retained and sealed with a strain relief gland

Standard Lower Seal material is Silicon Carbide

Shown: Integral Mounting Stand for transportable applications. Optional: HOMA AutoCoupling System for permanent installations

Upper and Lower High Capacity Ball Bearings assure long life and reliability

Motor windings provided with Class H insulation and fully protected by embedded auto reset thermal switches

Oil Filled Seal Chamber positively lubricates seals and permits a seal leakage probe to be installed

Single Vane impeller for large solids handling

Replaceable volute wear ring in single vane pump permits hydraulic efficiency to be restored for long service life

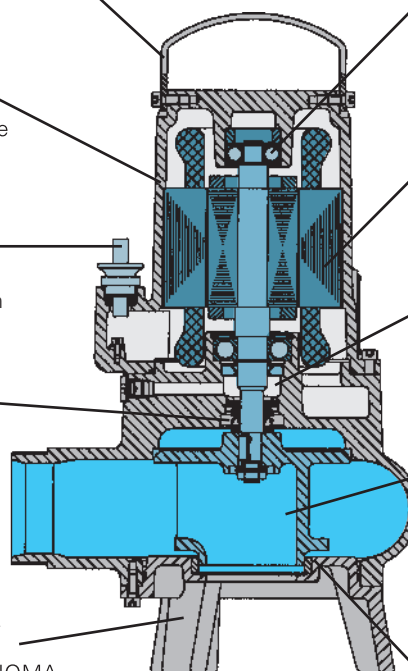

Motor Construction

Motor Type:

Enclosed Submersible

NEMA Insulation Code:

Class H

Service Factor:

1.15

NEMA Design Type:

B

Standard Cable Length:

33 ft

Available Motor Voltages:

1 Phase: 115 V, 200 V, 230 V

3 Phase: 200 V, 230 V, 380 V,
460 V, 575 V

Optional Explosion Proof

construction:

Factory Mutual approved for Class I,
Div. 1, Group C & D.

Installations

Wet pit with autocoupling

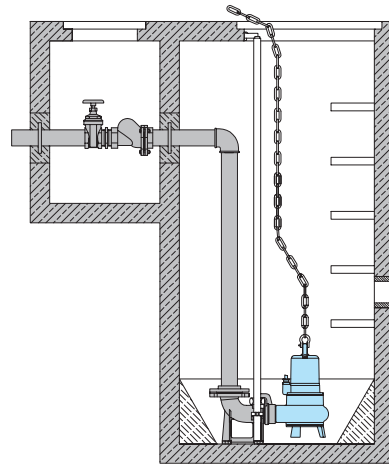

Basestand

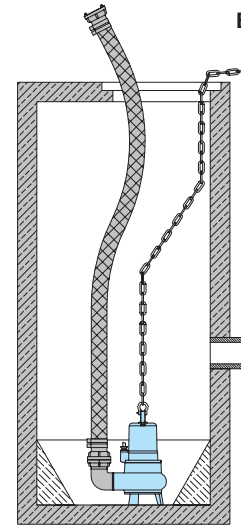

Materials

Motor Housing, Volute and Impeller

Cast Iron ASTM A 48, Class 40B

Mechanical Seals – Impeller side

Silicon Carbide vs Silicon Carbide

Shaft Seal – Motor side

Mechanical Seal

(Silicon Carbide vs Silicon Carbide)

TP50M16...-M24...: Lip Seal

O-Rings: Nitrile Rubber

Upper Bearing:

Deep groove Ball Bearing

Lower Bearing:

Double row angular Ball Bearing

TP50M16-M24 (not FM models):

Deep groove Ball Bearing

Power Cable Sheathing:

Nitrile Rubber

Shaft: AISI 430 F

Fasteners: AISI 304 SS

Dimensions (inches) (Tolerance +/- 1/4")

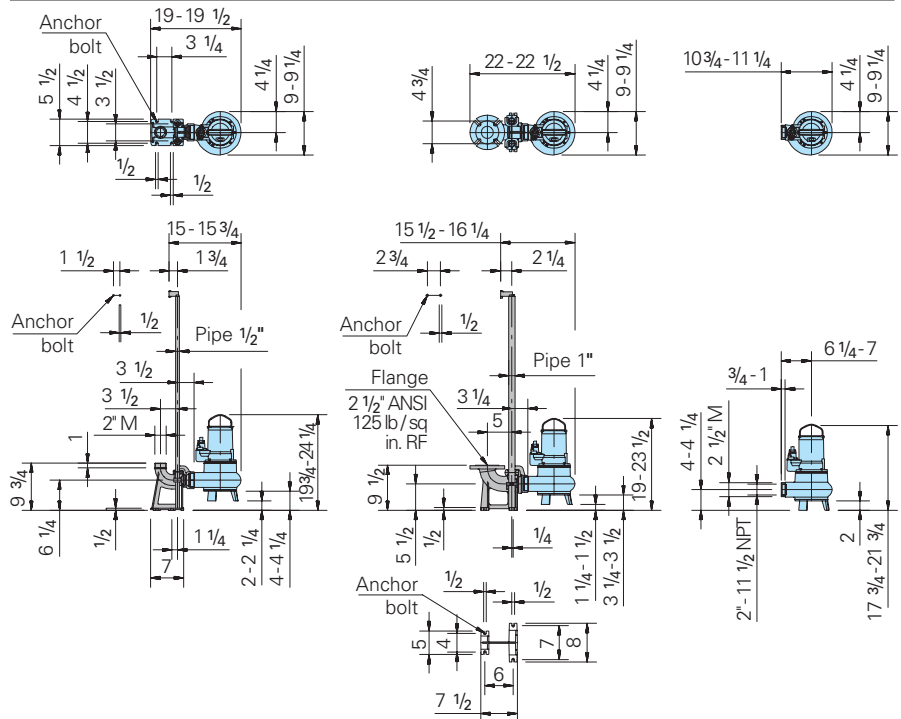

Technical Data

Curve No.	Pump Type	Rated B.H.P.	Phase	Voltage (V)	Full Load Amps	Speed (rpm)	Weight (LBS)	NEMA code
1	TP50M16/2/1	1.2	1	230	5.4	3450	57	F
2	TP50M24/2/1	1.7	1	230	7.8	3450	55	F
3	TP50M38L/2/1	2.6	1	230	12.0	3450	88	E
4	TP50M38H/2/1	2.6	1	230	12.0	3450	88	E
5	TP50M54L/2/1	4.3	1	230	18.5	3450	99	F
6	TP50M54H/2/1	4.3	1	230	18.5	3450	99	F
7	TP50M16/2/3	1.2	3	230/380/460	3.8/2.3/1.9	3450	57	G
8	TP50M24L/2/3	1.9	3	230/380/460	5.4/3.3/2.7	3450	55	G
9	TP50M24H/2/3	1.9	3	230/380/460	5.4/3.3/2.7	3450	55	G
10	TP50M38L/2/3	3.1	3	230/380/460	8.0/4.8/4.0	3450	88	F
11	TP50M38H/2/3	3.1	3	230/380/460	8.0/4.8/4.0	3450	88	F
12	TP50M54L/2/3	4.7	3	230/380/460	12.0/7.2/6.0	3450	99	F
13	TP50M54H/2/3	4.7	3	230/380/460	12.0/7.2/6.0	3450	99	F
14	TP50M23/4/3	1.6	3	230/380/460	5.2/3.2/2.6	1750	88	G
15	TP50M35/4/3	2.5	3	230/380/460	8.8/5.3/4.4	1750	99	G